

Switched Reluctance Motor for Hybrid Electric Vehicle

Sudiksha Srivastava (Scholar), Department of Electrical Engineering, Maharishi University of Information Technology, Lucknow

Pankaj Sahu (Department of Electrical Engineering, Maharishi University of Information Technology Lucknow)

Abstract

The Electric vehicles are becoming increasingly important as not only do they reduce dependence on oil, but also they can be used to minimize noise and pollution. There are many electric-propulsion systems for a Hybrid Electric Vehicle (HEV). The SRMs are gaining much interest and are recognized to have a potential for HEV applications because of its several advantage. There are, however, several disadvantages, which for many applications outweigh the advantage. The torque ripple, acoustic noise and speed ripple. The highly nonlinear nature of the SRM operating in saturation makes analytical modelling extremely difficult. The main aim of this project is to employ the non-linear controller for switched reluctance motor to reduce the torque and speed ripple to make it suitable for HEV.

INTRODUCTION

In this paper the switched reluctance motor is employed for hybrid electrical vehicle with low torque and speed ripple using non-linear controller. Simulink model for the speed control of switched reluctance motor is carried out using different speed controllers. The Simulink model is designed with PI and Fuzzy logic controller separately and their performance is compared. The Switched Reluctance Motor is an electric motor which runs by reluctance torque. The speed controllers applied here are based on PI Controller and the other one is AI based Fuzzy Logic Controller. The proportional integral controller (PI Controller) is a special case of the PID controller in which the derivative of the error is not used.

Hybrid Electric Vehicle:

A Hybrid Electric Vehicle (HEV) is a one that combines a conventional Internal Combustion Engine (ICE) propulsion system with a hybrid vehicle drive train. To reduce fossil energy consumption, the utilization of green energy sources has increasingly gained attention worldwide.

The series and parallel are the two type of HEV system. Selection of traction motors for hybrid electric vehicle is a very important step that requires special attention.

In an industrial point of view, the major types of electric motors adopted for HEVs as well as for EVs include the dc motor, the Induction Motor (IM), the Permanent Magnet (PM) Synchronous Motor and the switched reluctance motor (SRM).

In fact, the automotive industry is still seeking for the best electric propulsion system for hybrid electric vehicles (HEVs) and even for EVs.

Switched Reluctance Motor:

The SRM drives for industrial applications are of recent origin. A brief introduction of SRM and its principle of operation are explained in this chapter. A Switched Reluctance Motor is a singly excited, doubly-salient machine in which develop the electromagnetic torque due to variable reluctance principle. The stator only carries winding but both rotor and stator has salient poles. As in dc motor the SRM has wound field coils for stator windings. When the excitation due to the dc supply is given to the stator windings, a force is created by rotor's magnetic reluctance that aligns the adjacent stator pole with the rotor pole. In order to preserve sequence rotation, the stator pole windings switches in a sequential manner with the help of electronic control system so that the magnetic field of rotor pole was lead by the stator pole, pulling towards it. When the rotor pole is equidistant from the two adjacent stator pole the rotor pole is said to be in "fully unaligned position." This position is called as maximum magnetic reluctance for the rotor pole. The rotor poles are fully aligned with the stator poles in the aligned position, this position is called as minimum reluctance of rotor pole which consist 6 stator poles and 4 rotor poles.

Block Diagram:

The block diagram of SRM is shown in the above. When the Dc supply is given to the motor, starts to rotate. The rotor position sensor is used to sense the current position of the rotor and it provides output to the error detector. Error detector compares reference speed and actual speed. The controller gives control signal to the converter according to the error signal. The speed of the motor is controlled by the converter through proper excitation of their corresponding windings. Thus the switched reluctance motors operate.

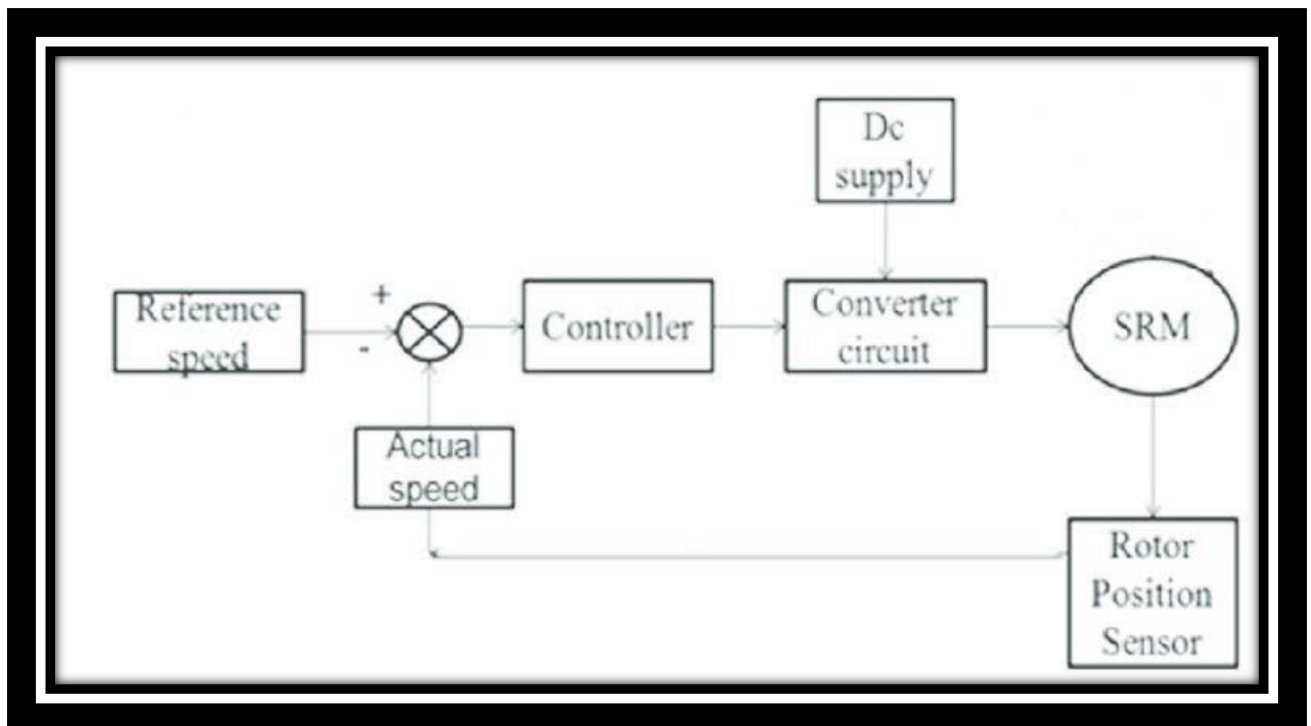

Block diagram of SRM speed control

Electrical vehicle (EV) based on electric propulsion system. No internal combustion engine is used. All the power is based on electric power as the energy source. The main advantage is the high efficiency in power conversion through its proposition system of electric motor. Recently there has been massive research and development work reported in both academic and industry. Commercial vehicle is also available. Many countries have provided incentive to users through lower tax or tax exemption, free parking and free charging facilities. On the other hand, the hybrid electric vehicle (HEV) is an alternative. It has been used extensive in the last few years. Nearly all the car manufacturers have at least one model in hybrid electric vehicle. The questions come to us: Which vehicle will dominate the market and which one is suitable for future? This paper is to examine the recent development of electric vehicle and suggest the future development in the area.

Speed Control of Srm Using PI Controller:

The forced oscillation and steady state error are eliminated by PI controller. Thus, PI controller will not increase the speed of response. PI controller does not have means to predict what will happen with the error in near future by introducing the derivative mode this problem have been solved and thus to decrease a reaction time of the controller.

$$\Delta = SP - PV$$

Where delta is the error or deviation of actual value (PV) from the set point (SP).The Proportional-Integral (PI) algorithm computes and transmits a controller output signal every sample time, to the final control.

The Motors

There are a number of motors available for electric vehicle: DC motors, Induction motor, DC brushless motor, permanent magnetic synchronous motor and Switched reluctance motor.

DC Motors:

It is a classical motor and has been used in motor control for a long time. All the power involved in electromechanical conversion is transferred to the rotor through stationary brushes which are in rubbing contact with the copper segments of the commutator. It requires certain maintenance and has a shorter life time. However, it is suitable for low power application. It has found applications in electric wheel-chair, transporter and micro-car. Today, most of the golf-carts are using DC motors. The power level is less than 4Kw

Induction motor

It is a very popular AC motors. It also has a large market share in variable speed drive-application such as air-conditioning, elevator or escalator. Many of the higher power electric vehicles, for more than 5kW, uses induction motor. Usually a vector drive is used to provide torque and speed control.

DC brushless motor

The conventional DC motor is poor mechanically because the low power winding, the field, is stationary while the main high power winding rotates. The DC brushless motor is "turned inside out. The high power winding is put on the stationary side of the motor and the field excitation is on the rotor using a permanent magnet. The motor has longer life time than the DC motor but is a few times more expensive. Most of the DC motor can be replaced by the brushless motor with suitable driver. Presently, its applications find in low power EV.

Permanent magnetic synchronous motor

The stator is similar to that of an induction motor. The rotor is mounted with permanent magnets. It is equivalent to an induction motor but the air-gap field is produced by a permanent magnet. The driving voltage is sine wave generated by Pulse Width Modulation (PWM). 5. Switched reluctance motor It is a variable reluctance machine and its famous recently because of the fault tolerance because each phase is decoupled from other. The power stage is different from other the motor discussed in 2-4. Each phase winding is connected in a fly back circuit style

CONCLUSION

SRM has been designed and implemented for its speed control by using PI controller and AI based fuzzy logic controller. We can conclude from the simulation results that when compared, the fuzzy Logic Controller FLC is more advantaged than the PI. We can conclude from the simulation results that the Switched reluctance motor with low torque and speed ripple is the good electric-propulsion system for hybrid electric vehicle. This paper discusses the recent development in electric vehicle. The paper first describes general structure and discusses the energy storage. It then extends to the future vehicle components. The paper provides an overview of the recent EV work in the region

REFERENCES

1. Emadi, K. Rajashekara, S.S. Williamson and S.M. Lukic, 2005. "Topological over view of hybrid electric and fuel cell vehicular power system architectures and configurations," IEEE Trans. Veh. Technol., 54(2): 736-770, May 2005.
2. Rodrigues, M.G., W.I. Suemitsu, P. Branco, J.A. Dente and L.G.B. Rolim, 1997. Fuzzy logic control of a switched reluctance motor. Proceedings of the IEEE International Symposium, 2: 527-31.
3. Miller, T.J.E., 1993 Switched Reluctance Motors and Their Control. Oxford, U.K.: Clarendon
4. Jones, W.D., "Hybrids to the rescue [hybrid electric vehicles]", IEEE Spectrum, Vol. 40(1), 2003, pp. 70 – 71.
5. Jones, W.D., "Take this car and plug it [plug-in hybrid vehicles]", Spectrum, IEEE, Vol. 42, Issue 7, July 2005, pp. 10 – 13.
6. Jones, W.D., "Putting Electricity Where The Rubber Meets the Road [NEWS]", IEEE Spectrum, Vol. 44, Issue 7, July 2007, pp. 18 – 20.
7. Affanni, A.; Bellini, A.; Franceschini, G.; Guglielmi, P.; Tassoni, C., "Battery choice and management for new-generation electric vehicles", IEEE Trans. on Industrial Electronics, Vol. 52(5), Oct. 2005, pp. 1343 – 1349
8. Chan, C.C. The Present Status and Future Trends of Electric vehicles, Science and Technology Review, Vol. 23, No. 4, Feb 2005

9. K.W.E.Cheng, “Tapped inductor for switched-mode power converters”, 2nd Int. Conference on Power Electronics Systems and Applications, 2006, pp. 14-20.